

MS. CATALOGUE

(Marbled Salts) redefines material and meaning through a unique sea salt-based composite that bridges the worlds of art and design. Each creation embodies a dialogue between nature and craftsmanship, revealing the quiet strength of transformation. Guided by ecological awareness and a sculptural sensibility, the studio offers timeless pieces where innovation, beauty, and integrity converge.

Each of our project testifies our commitment to sustainability, local craftsmanship, and artistic integrity.



ABOUT

Craftmanship .5
The designer .6

CORE

Dining tables
Side tables
Coffee tables
Lights .7

COLLECT

Dining tables
Side tables
Coffee tables
Seats
Consoles
Lights
Accessories .47

THANKING

.83



The sea salt comes from salt marshes in South of France where it was already harvested long before the Roman Empire. In our workshop, it is humidified, mixed with organic binders, powdered pigments, and pressed in molds. For a couple of days, the pieces are dried at a low temperature, before unfolding, polishing and varnishing. Every piece is handmade & unique by nature, and delivered with an authenticity certificate.

By transforming raw salt into a noble material, Marbled Salts redefines the limits between art, design, and sustainability. Our brand offers a refined, conscious vision of contemporary creation — where material innovation serves both beauty and purpose. Each piece tells a story of transformation: from ephemeral matter to lasting emotion.

Roxane Lahidji is a social designer specializing in ecological material developments and applications. Her research focuses on achieving luxurious-looking objects and surfaces from low costs and raw resources. With the deep concern of conciliating production and sustainability, her design uses disregarded or cheap materials brought to a new life, while twisting low-tech methods and traditional crafts techniques. After graduating from the Social Design department of Design Academy Eindhoven in 2017, Roxane Lahidji developed her project “Marbled salts” and was awarded among the 100 best French international designers by FD100 price of the VIA and won the 2019 Bolia award. Recently she was awarded by Wallpaper magazine with her Yubiwa side table amongst the “best elements of surprises”. Her pieces are now sold, shipped and shown internationally in galleries and museums.

The Design Museum of Ghent, the CID Grand Hornu and the Musée des Arts Décoratifs de Paris notably acquired Marbled Salts pieces for their permanent design collection.





TABLES



SABA

240x130x70cm
180kg

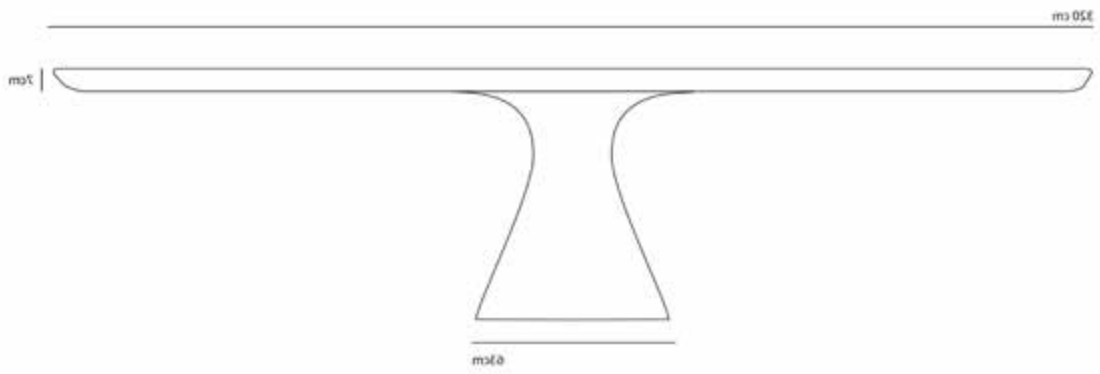
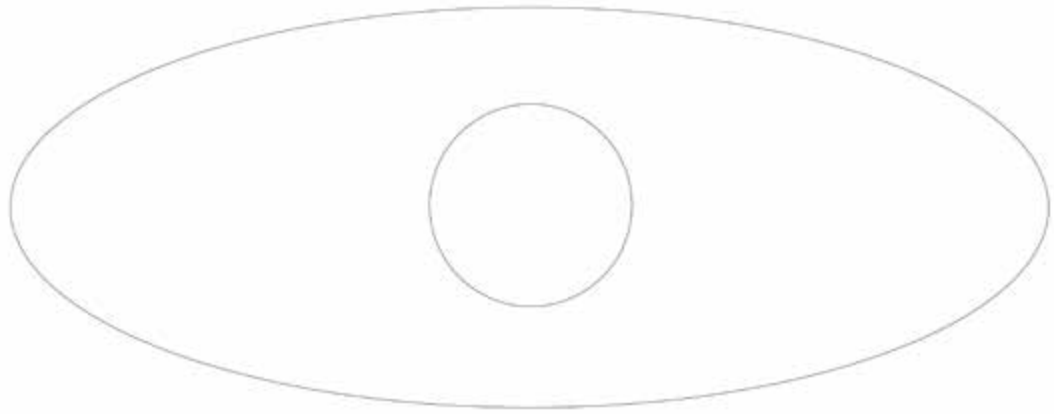



PROCESS

Marbled Salts Studio's process begins with material research. Sea salt is not treated as a substitute for stone, but as a living material with its own behaviors, limits, and possibilities. Through continuous experimentation, the studio develops proprietary recipes that allow salt to crystallize, bind, and harden, revealing textures and veining that emerge naturally rather than being imposed.

Each piece is shaped through a slow, hands-on approach. Casting, curing, carving, and finishing are carried out with careful attention to time, humidity, and touch. The process leaves room for chance: crystallization patterns, color variations, and surface irregularities are embraced as integral parts of the object's identity, making every piece unique.



CORE-TABLES_HANA DINING



HANA DINING

Dia.130
Height 70cm
120kg

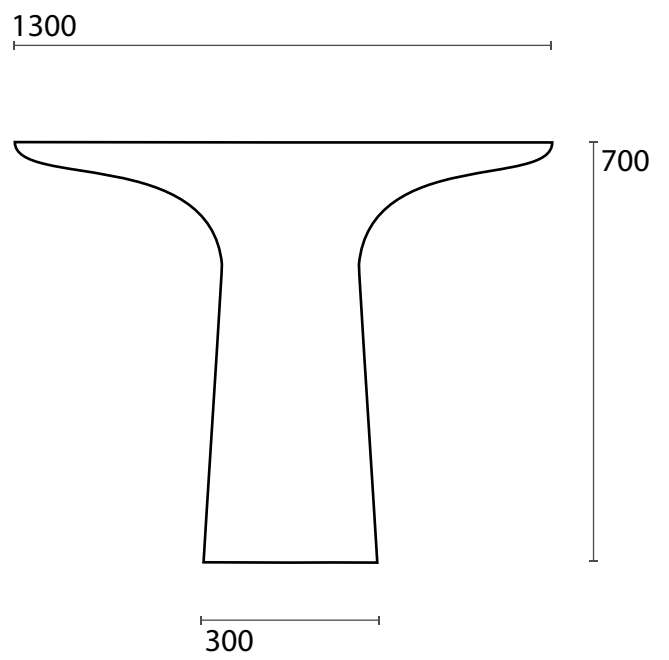
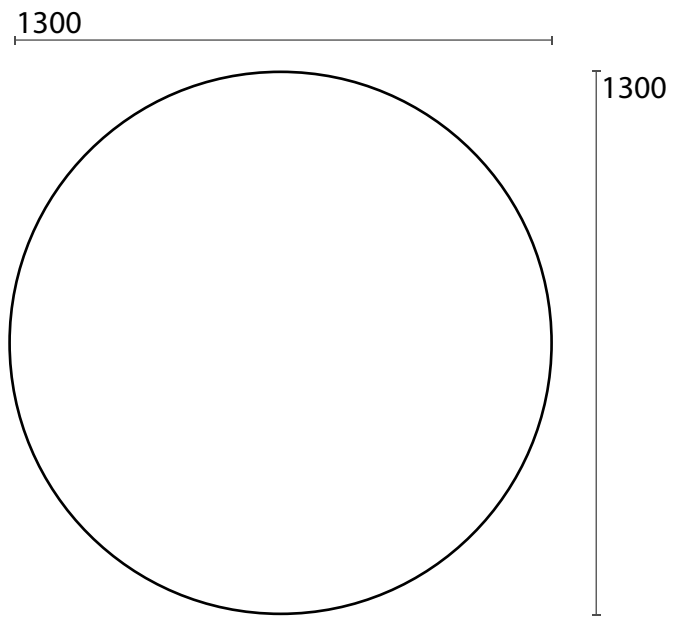

CORE-TABLES-DINING _ HANA



HANA

Dia.70- Height 70cm
80kg

700

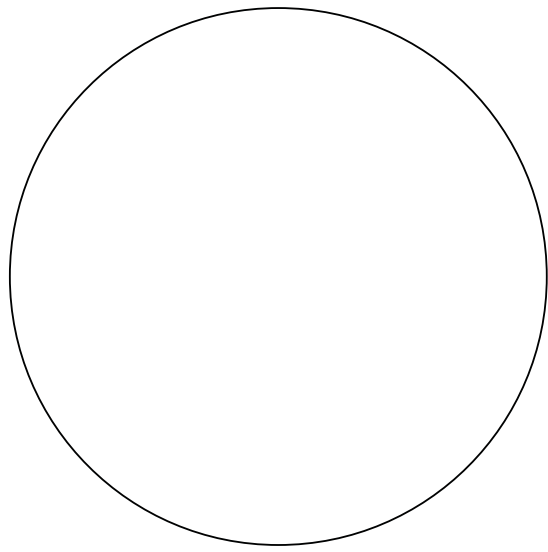

700



700

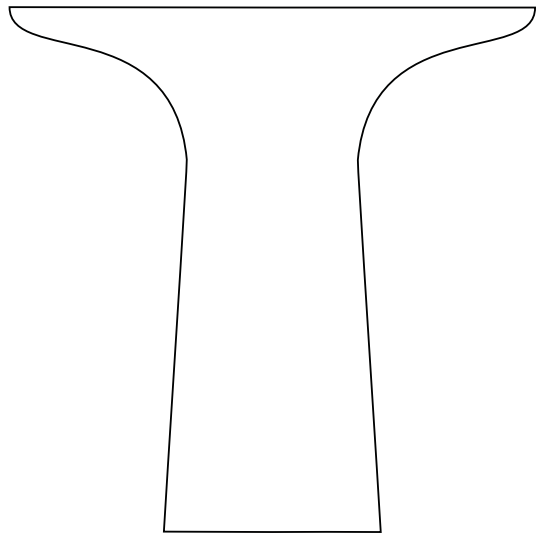

700



300

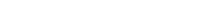

VISION

At Marbled Salts, we strive to reconnect our audience—collectors, visitors, and collaborators alike—with their sense of wonder and curiosity.

Each creation is an invitation to rediscover the child-like joy of observation and imagination. Through the interplay of color, contrast, and form, our pieces breathe poetry into the everyday.

They bring softness and spontaneity back into spaces often defined by structure and repetition.

We believe that true elegance and rarity lies truly in process—in the care, experimentation, and emotion invested in each gesture. Our work seeks to remind that preciousness can emerge from the organic, and that beauty, when shaped by hand and heart, reconnects us with our true nature.



Bespoke sculptural sink
175x45x25cm
2024

CORE-TABLES-SIDE - HANA COFFEE



HANA COFFEE

Dia.45cm
Height 45cm
25kgs

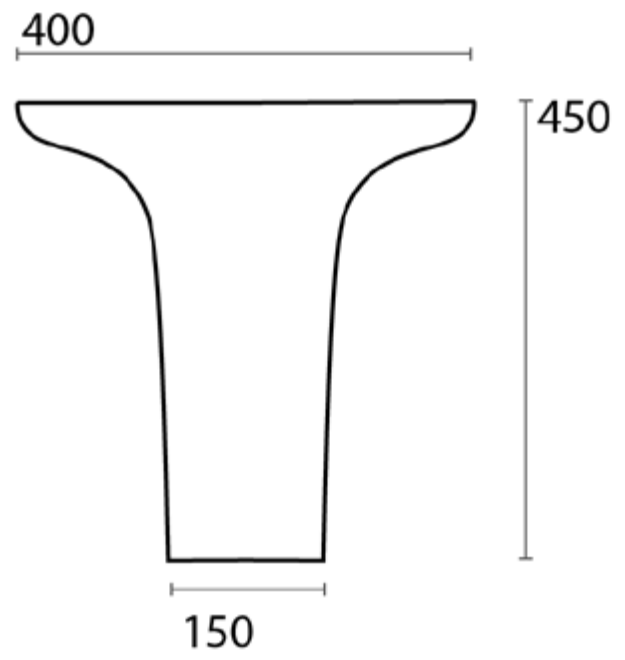
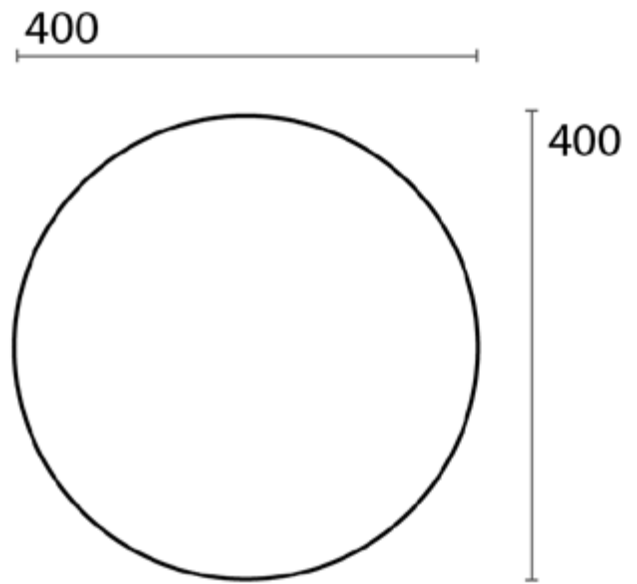

CORE-TABLES-SIDE_SHIBUI



HANA LOW

Dia. 70- Height 45cm
50kg

700

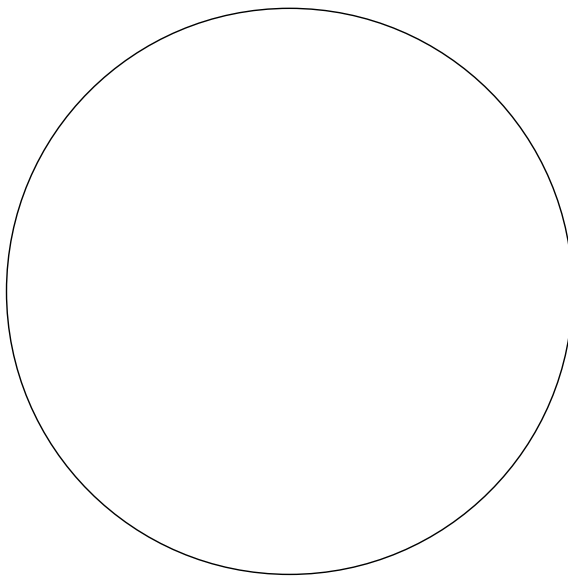

700

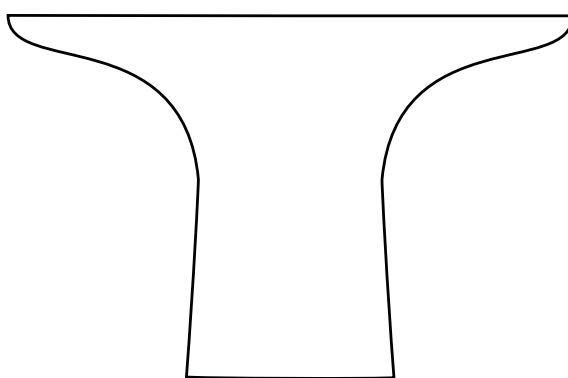

450

270



CORE-TABLES-LOW _NAMI



NAMI

120x70x45cm
85kg



CORE-TABLES-LOW __ COLLECTIBLE __ NIMBUS



NIMBUS

120x60x45cm
80kg









T TABLE

60x40x50cm
50kg

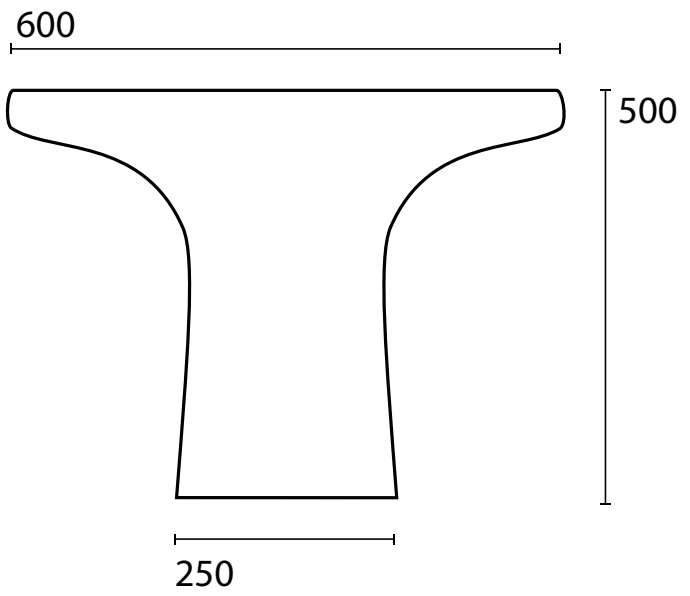
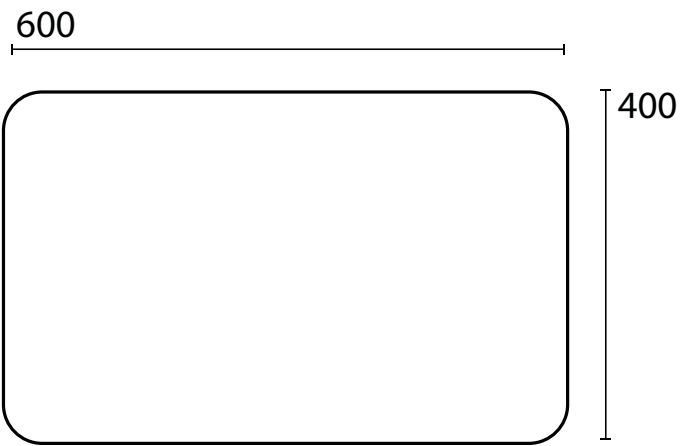

CORE-TABLES-SIDE _ HANA



HANA SIDE

Dia. 45- Height 60cm
45kg

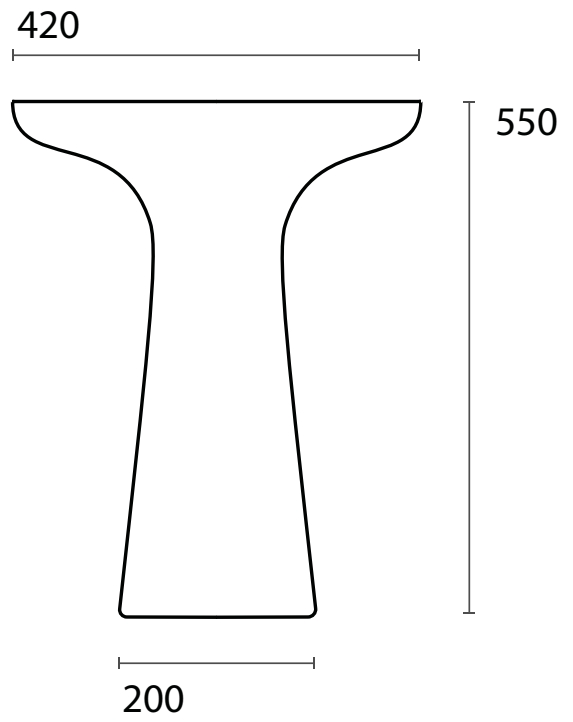
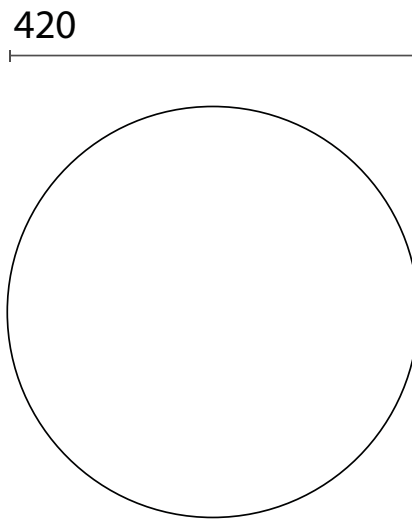

CORE-SEATS__OVAL



OVAL

40x38x50cm
50kg

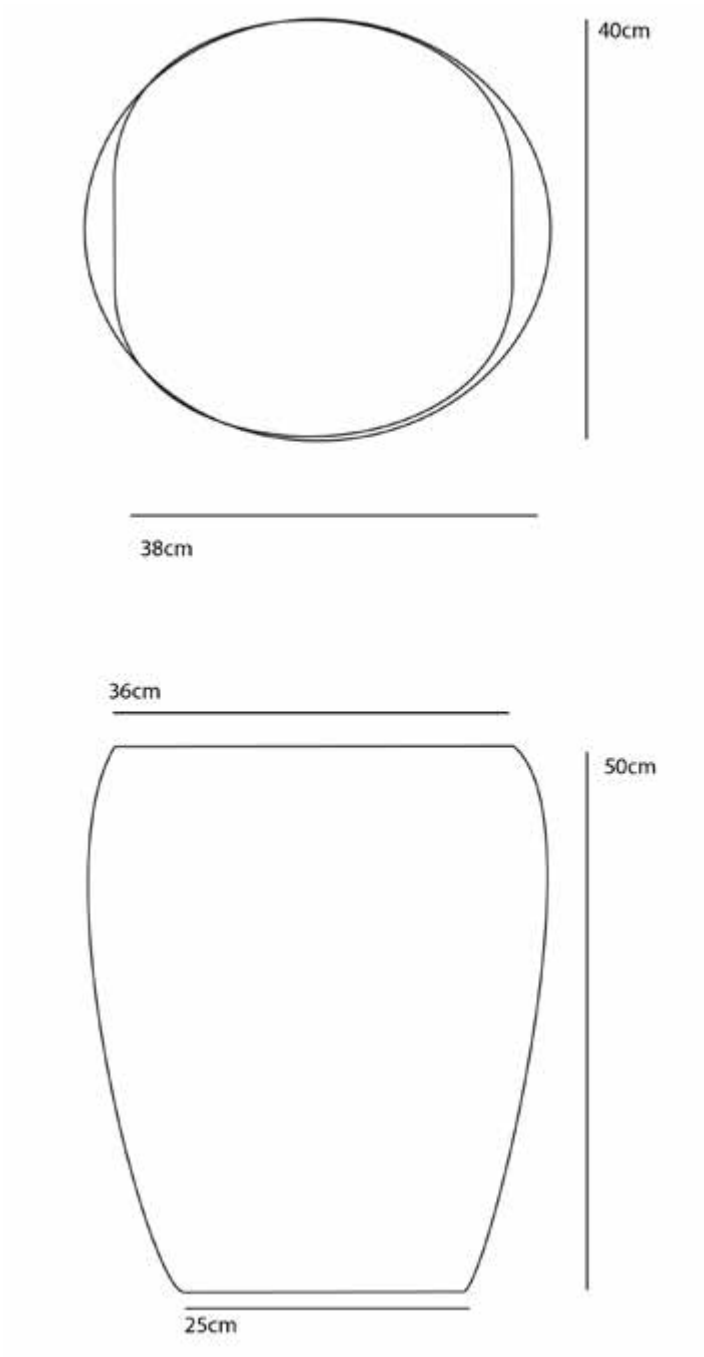



VALUES

Founded in 2018, Marbled Salts redefines material and meaning through a unique sea salt-based composite that bridges the worlds of art and design.

Each creation embodies a dialogue between nature and craftsmanship, revealing the quiet strength of transformation.

Guided by ecological awareness and a sculptural sensibility, the studio offers timeless pieces where innovation, beauty, and integrity converge.

Each of our projects testifies our commitment to sustainability, local craftsmanship, and artistic integrity.

LIGHTS







PLANET XL
50x50x40cm

Our first large lamp,
a literal planet in your
home.

From 25 to 35 kg

Available in
60cm
50cm
40cm

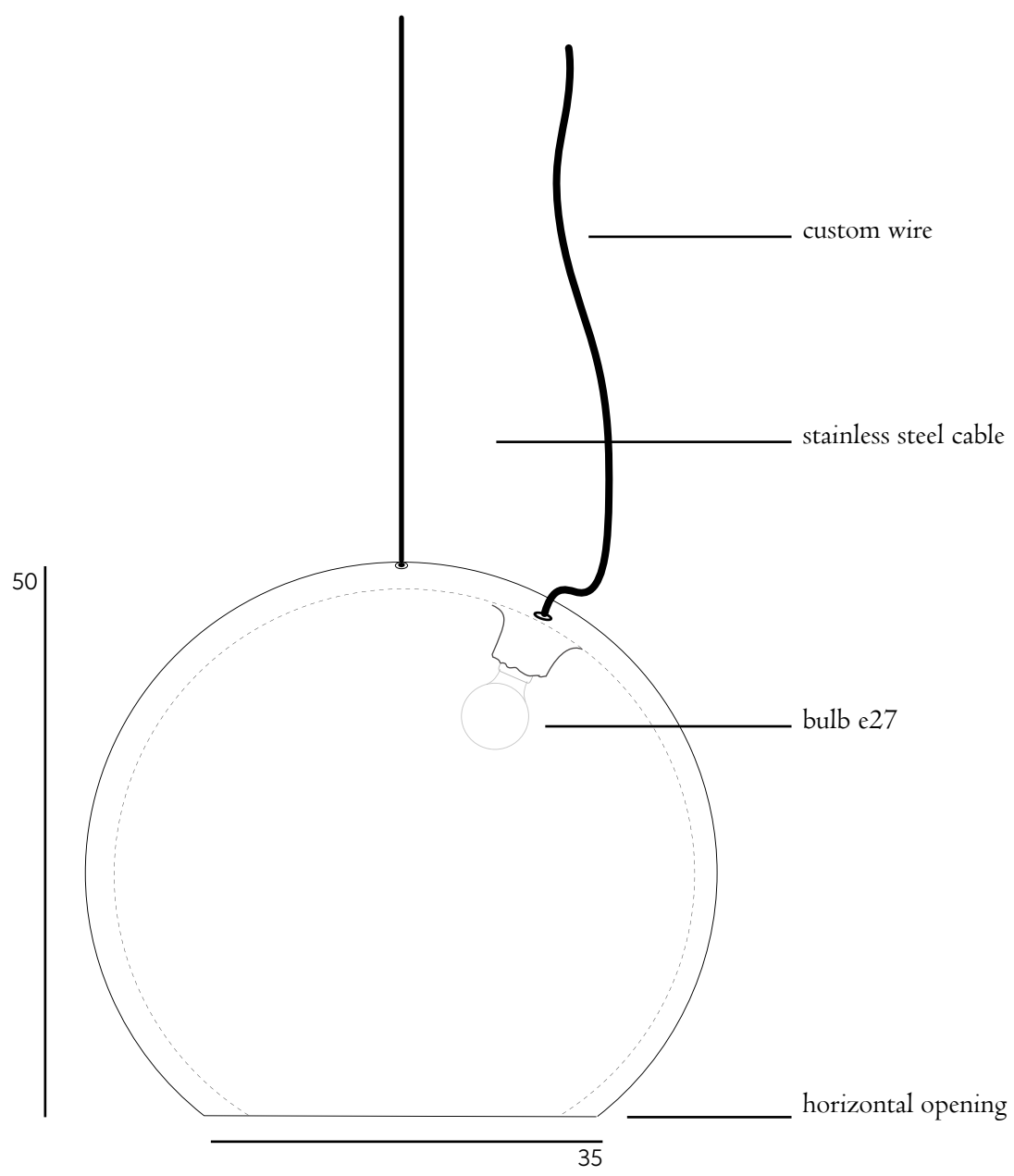

CORE-LIGHTS__STAND



STAND
25x20cm

A minimalistic yet beautiful option for your nightstands or on the floor itself.

Available in
60cm
50cm
40cm

25

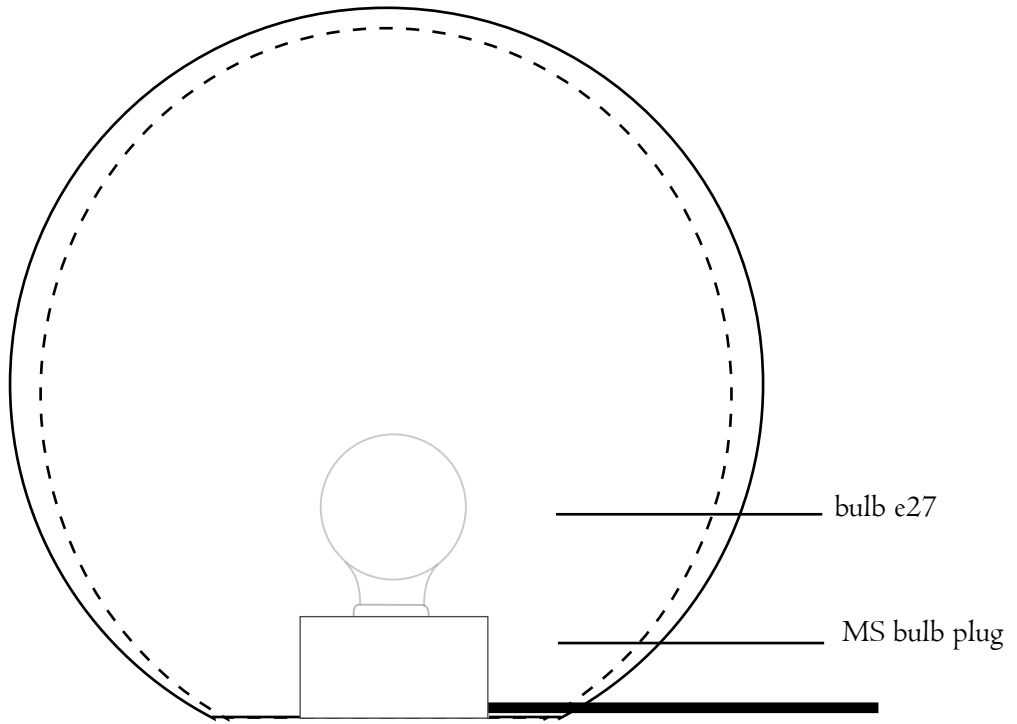

12



PLANET
25x20cm

Our best seller:
A classic look with a
contemporary twist.
Available with a vertical
or diagonal opening.

Available in
30cm
25cm
18cm

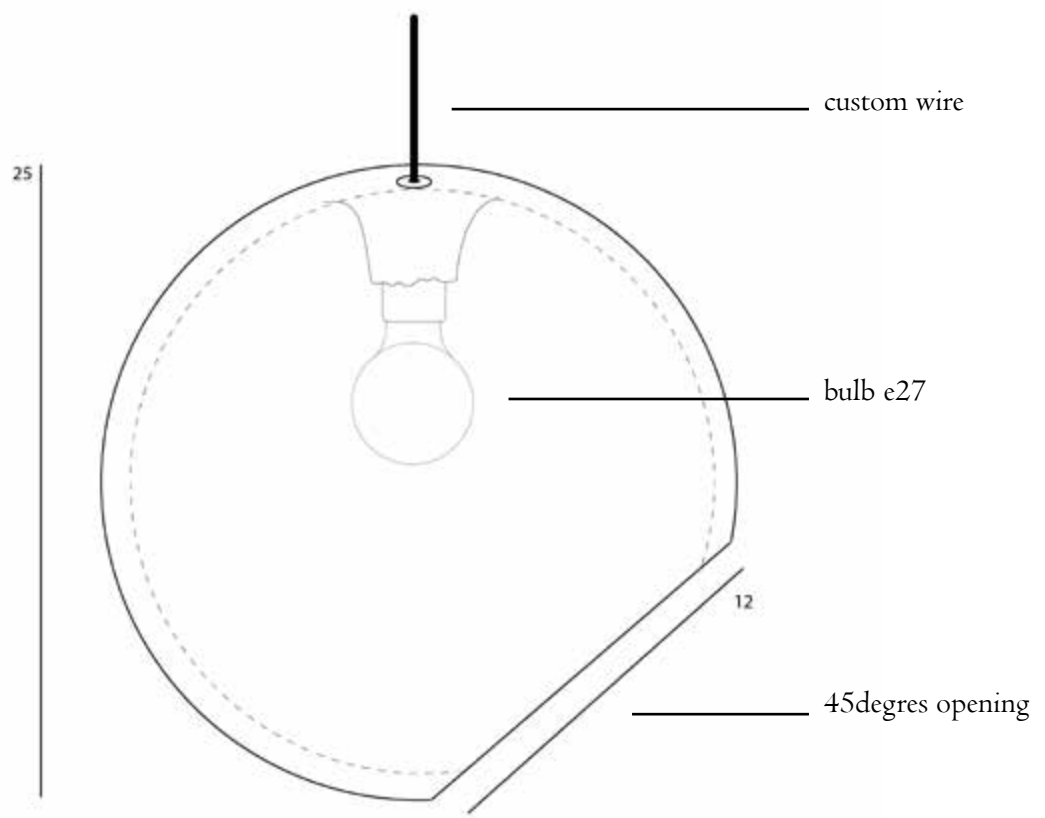



HANA
25x20cm

Our first lamp with a closed bottom, the bulb remains easily removable while preserving a smooth and clean look.

Available in
30cm
25cm
18cm

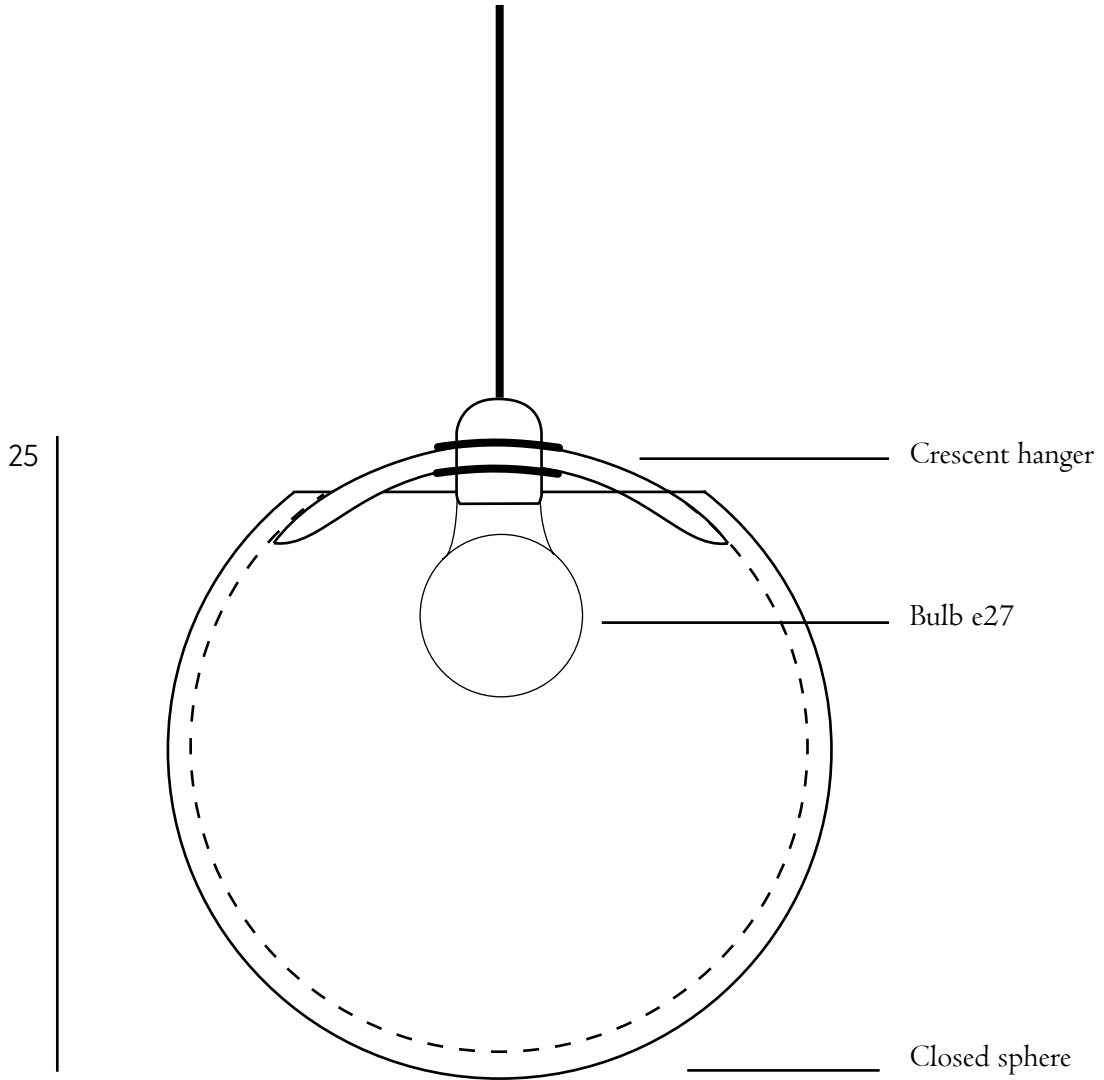

CORE-LIGHTS - PLANET MINI



PLANET MINI
14x14x12cm

A mini model that is easily
imagined in groupe of
constellations, hence its
name: Astra, whichs stands
dor "Star" in Ancient greek.

Available in:
16cm
14cm
12cm

14

8

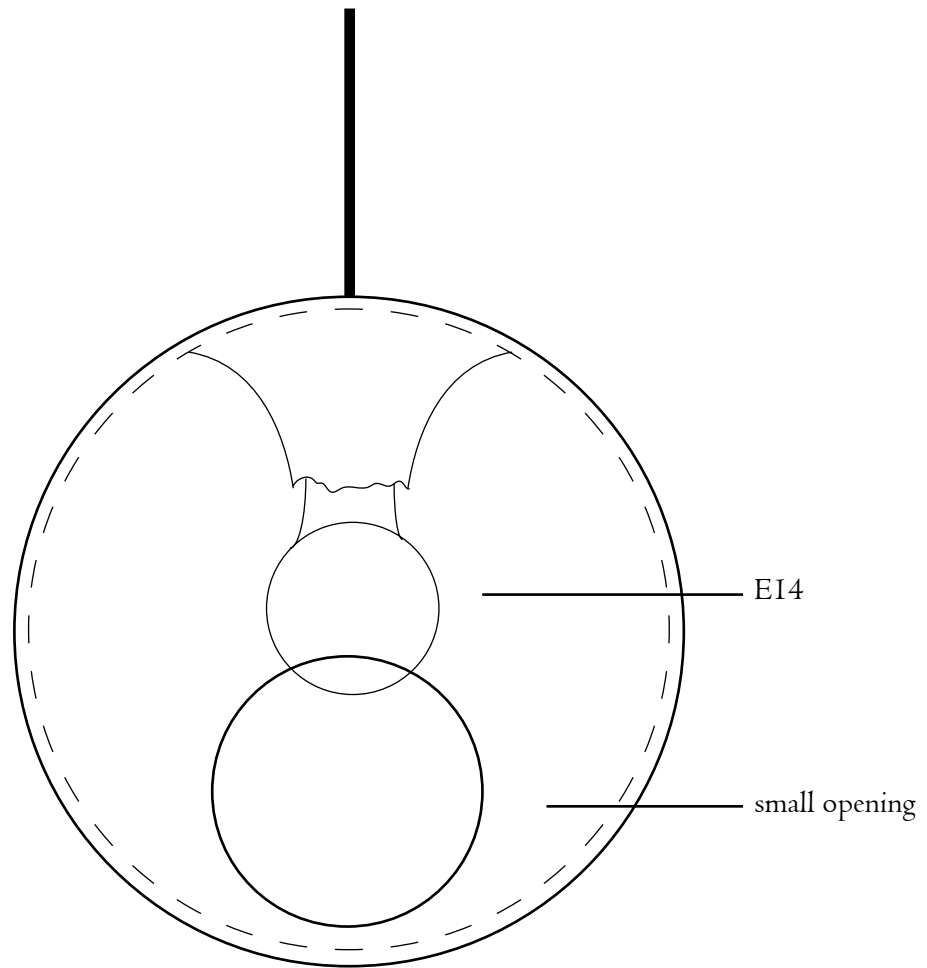



COLLECT
Collection

COLLECT-TABLES-DINING_ICARUS



ICARUS

320x1250x75cm
150kg

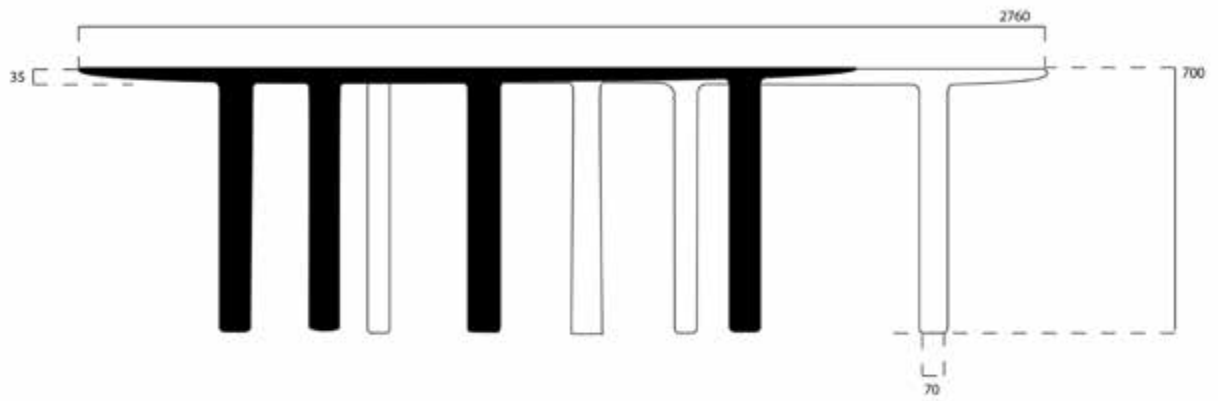
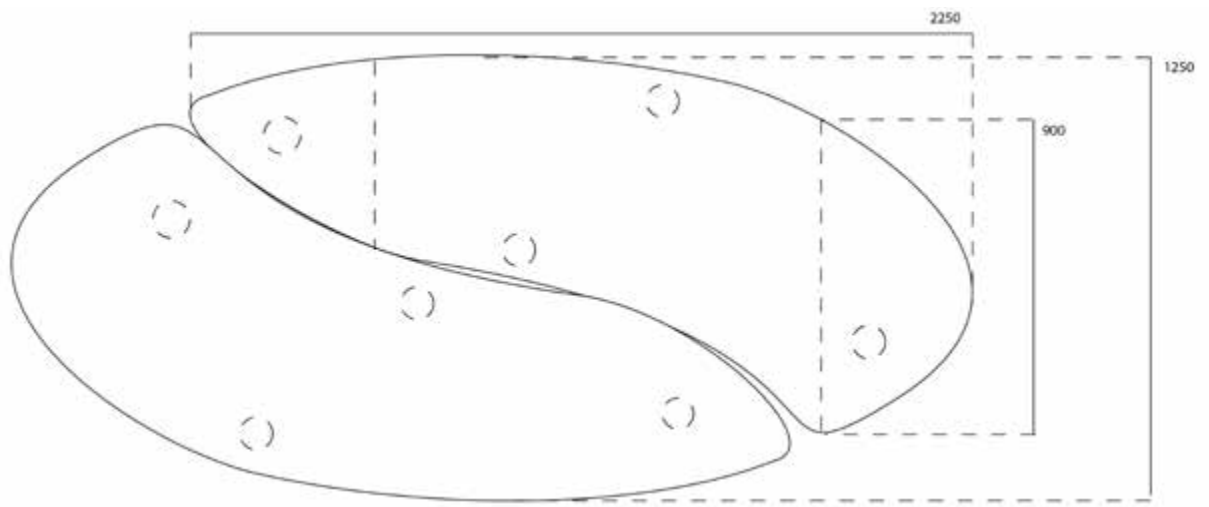

COLLECT-TABLES-DINING_KINOKO



KINOKO

Dia.70- Height 70cm
65kg

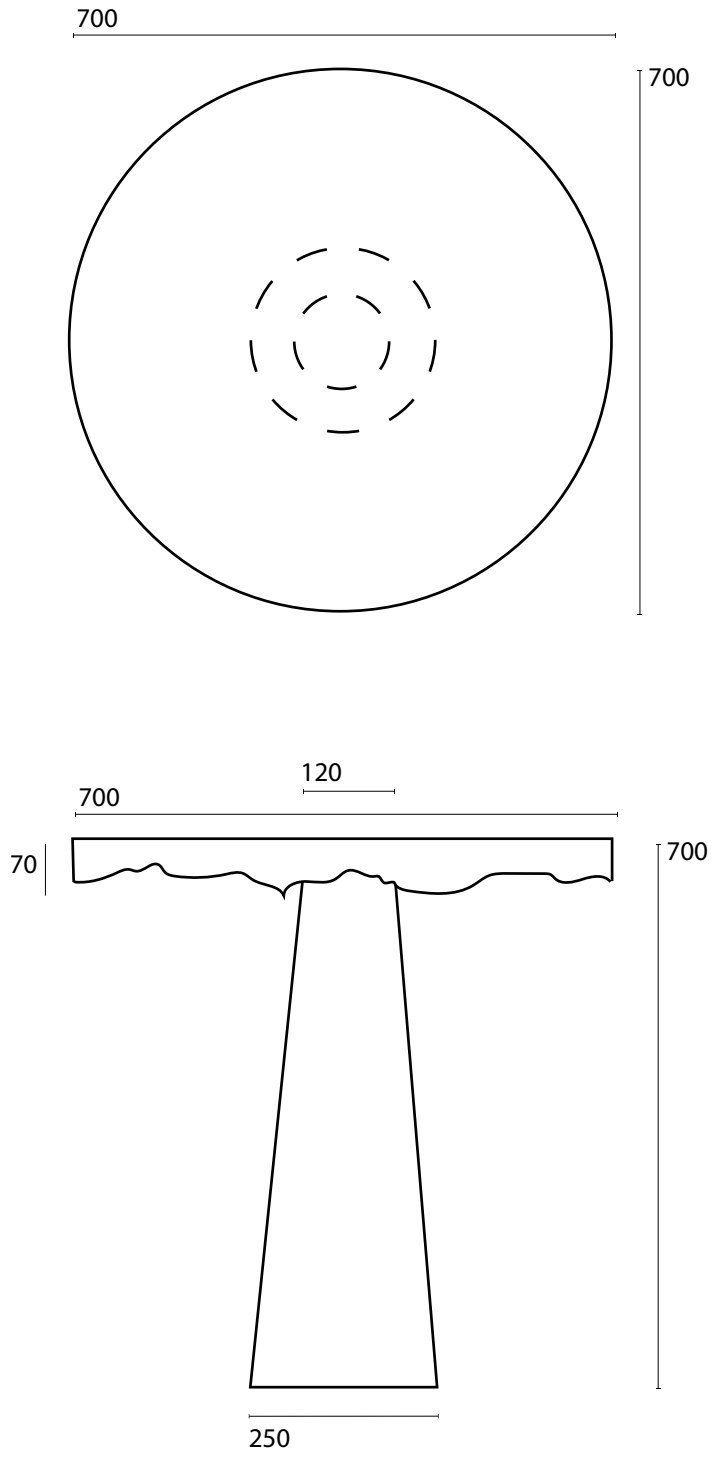

COLLECT-TABLES-SIDE _ KINOKO



KINOKO

45x45x50cm
25kg

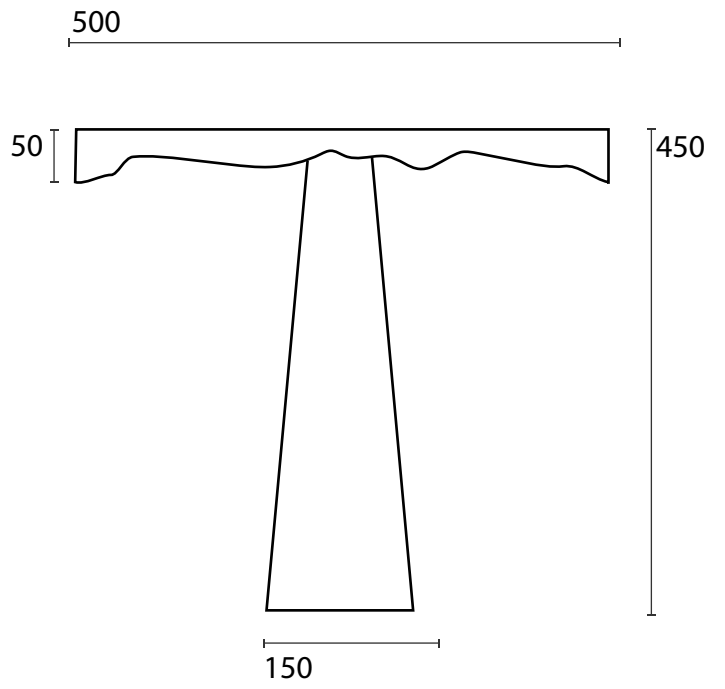
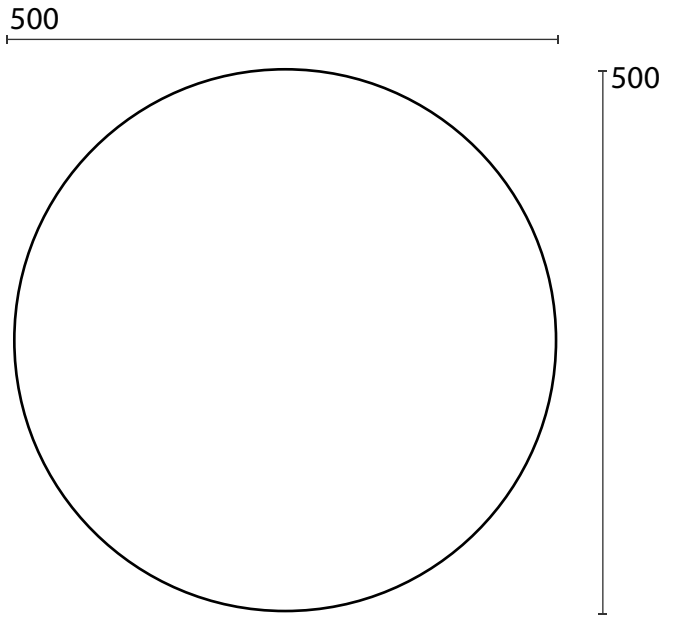



LOW KINOKO

60x60x38cm
About 40kg

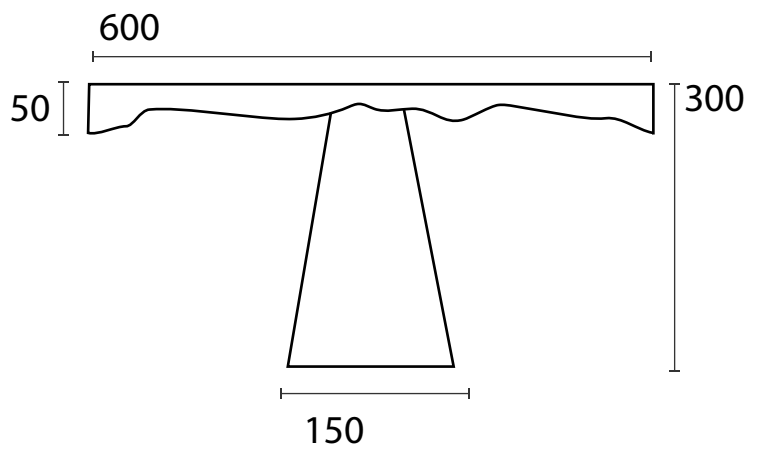
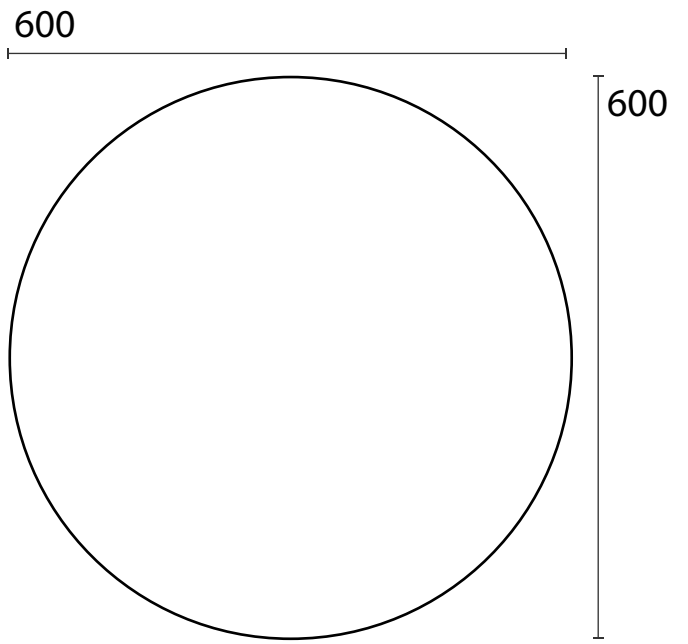

COLLECT-TABLES-SIDE_YUBIWA



YUBIWA

40x40x45cm

30kg



400

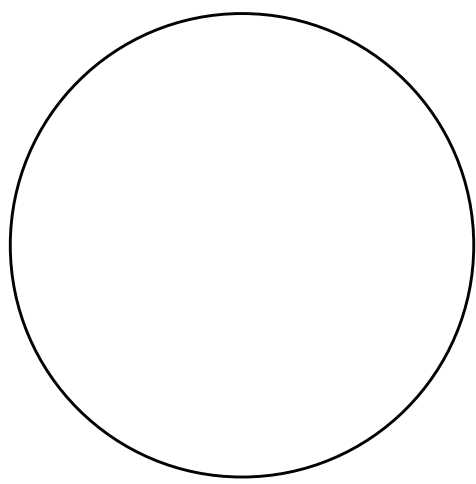

400

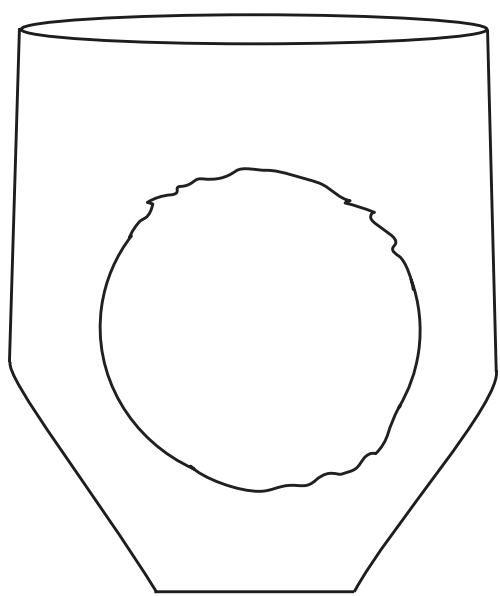

450

COLLECT-TABLES-SIDE__APPLE



APPLE

40x40x50cm
50kg

450

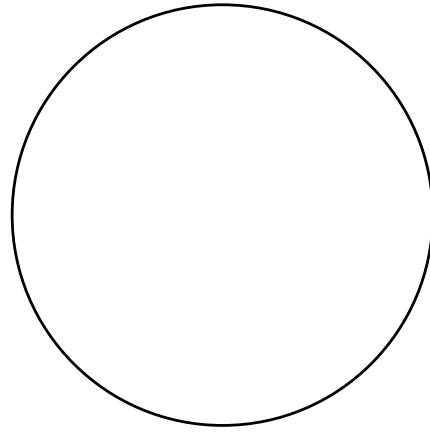

450

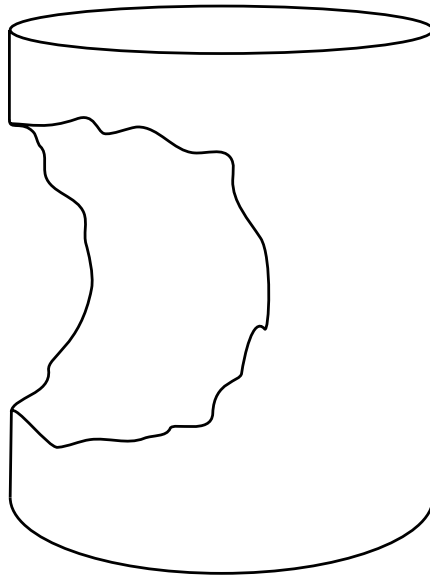

500



COLLECT-TABLES-LOW_NAGARE



BOOMERANG

160x70x40cm
150kg



COLLECT-TABLES-LOW__BOOMERANG



BOOMERANG

160x70x45cm
150kg



SEATS

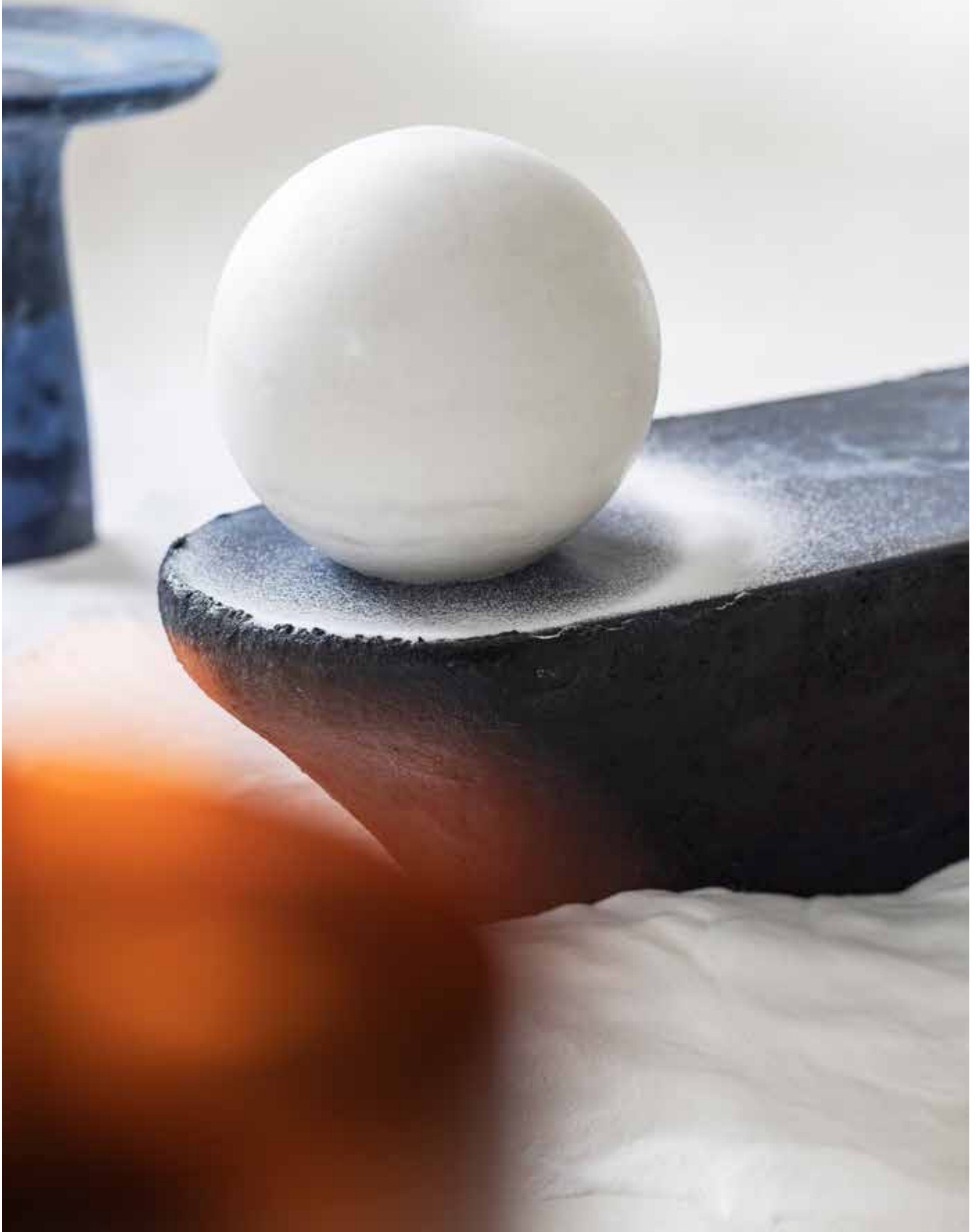



COLLECT-SEATS - BENCH_OVAL



OVAL

170x45x40cm
120kg

140cm

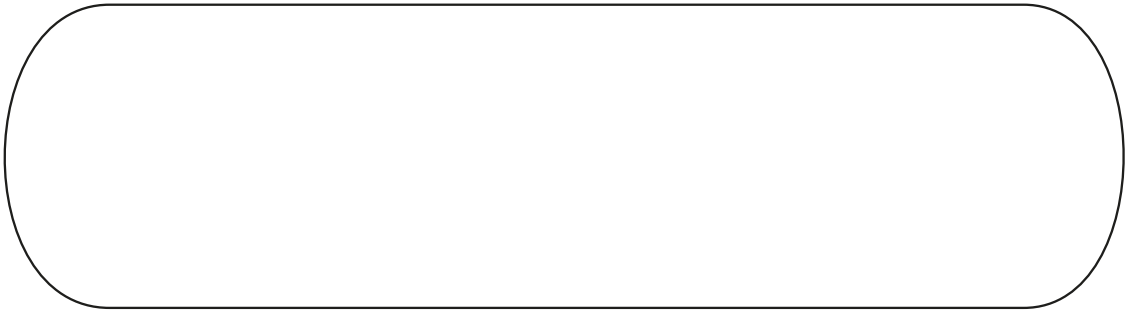

45cm

170cm

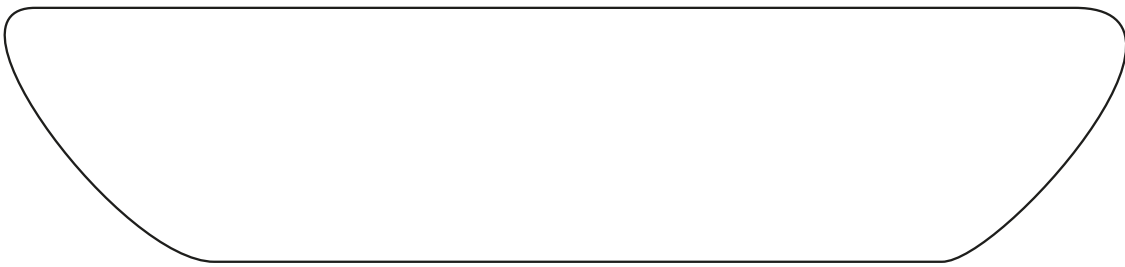

40cm



MISSION

Marbled Salts Studio explores the poetic potential of materials by transforming sea salt into sculptural objects that blur the boundaries between art and design. Rooted in material research and slow craftsmanship, the studio creates singular pieces that evoke natural stones such as marble or alabaster while offering an ecological alternative grounded in experimentation and care.

Each object is conceived as a meeting point between matter, time, and emotion — celebrating irregularity, fragility, and transformation rather than perfection or standardization. By embracing the unpredictable behavior of materials, Marbled Salts Studio allows form to emerge organically, giving each piece its own identity and narrative.



CONSOLES





SENSAI

100x100x45cm
75kg

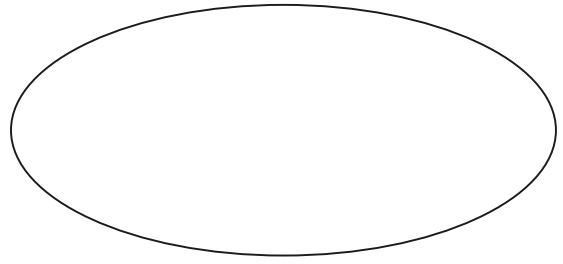

45

100

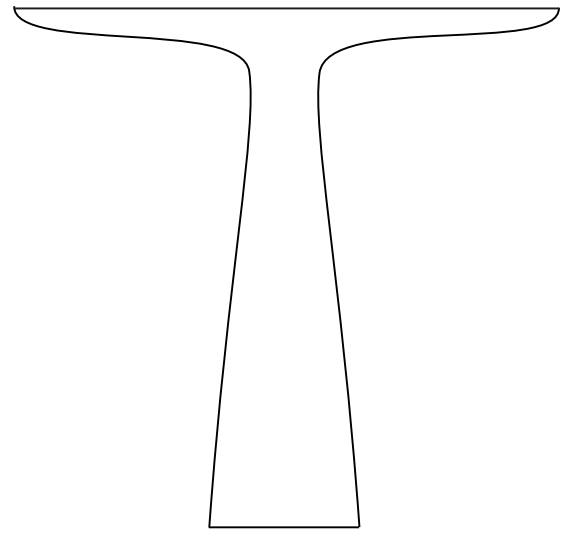

100

100

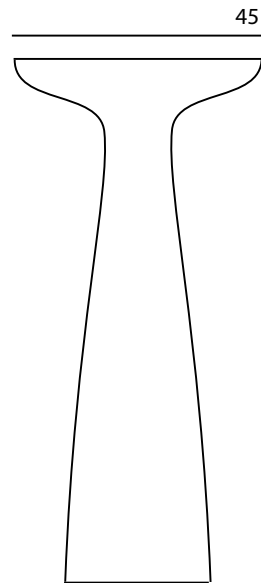

45

25

COLLECT-LIGHTS__CONE



CONE
40x22cm

A delicate and beautiful option for your interior projects, its shape and organic finish makes it both simple and uniques.

Available in
20cm
30cm
40cm

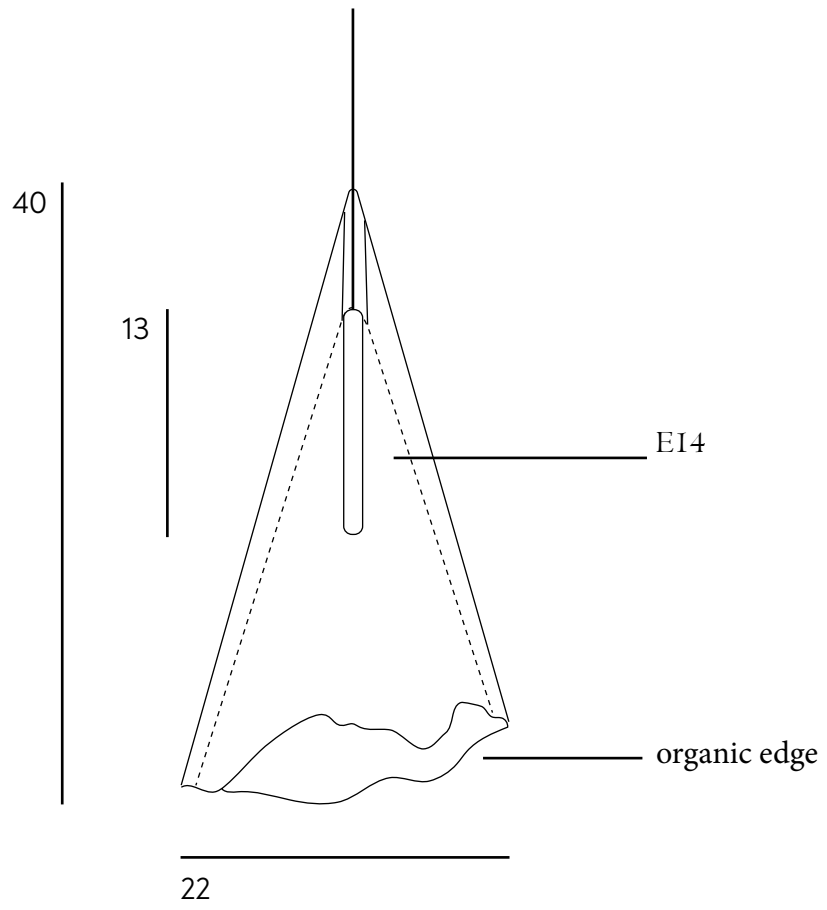

COLLECT-LIGHTS - FROST



FROST
40x40x22cm

A delicate and beautiful option for your interior projects, its shape and organic finish makes it both simple and uniques.

Available in
20cm
30cm
40cm

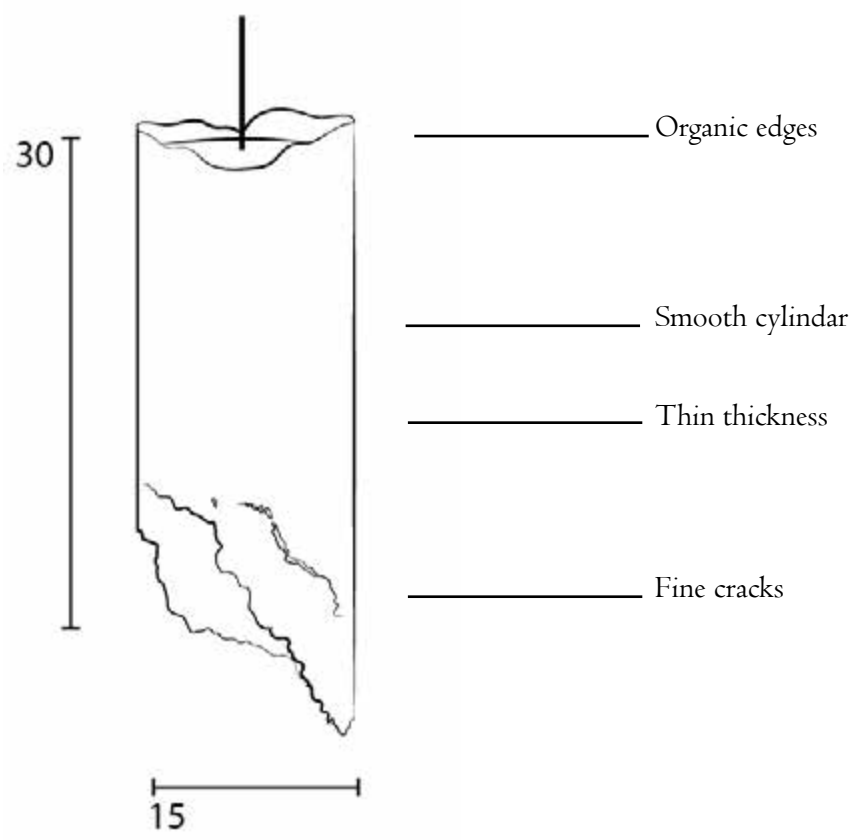



ACCESSORIES



COLLECT-ACCESSORIES - YUKI BOWL



YUKI
15x40cm

A delicate ornament for you interior. Our Yuki bowl is a minimalistic concentrate of our Know how: It combines a contrast of both silky and snowy textures, a balance of weight and proportions as well as an ethereal materiality.

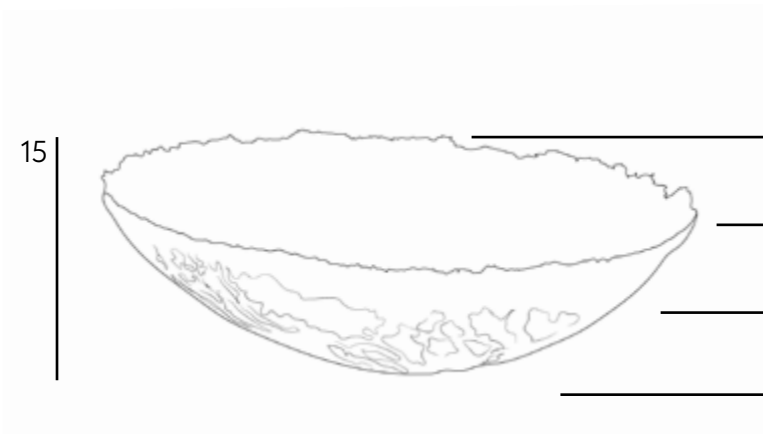

Shell effect

Smooth inside

food compatible

Frosty surface

15

40



YUKI VASE
35x15cm

A limited edition of ten vases, seemingly carved from one block and chiseled by hand, making each piece singularly unique.

35



Organic edges

Snowy texture

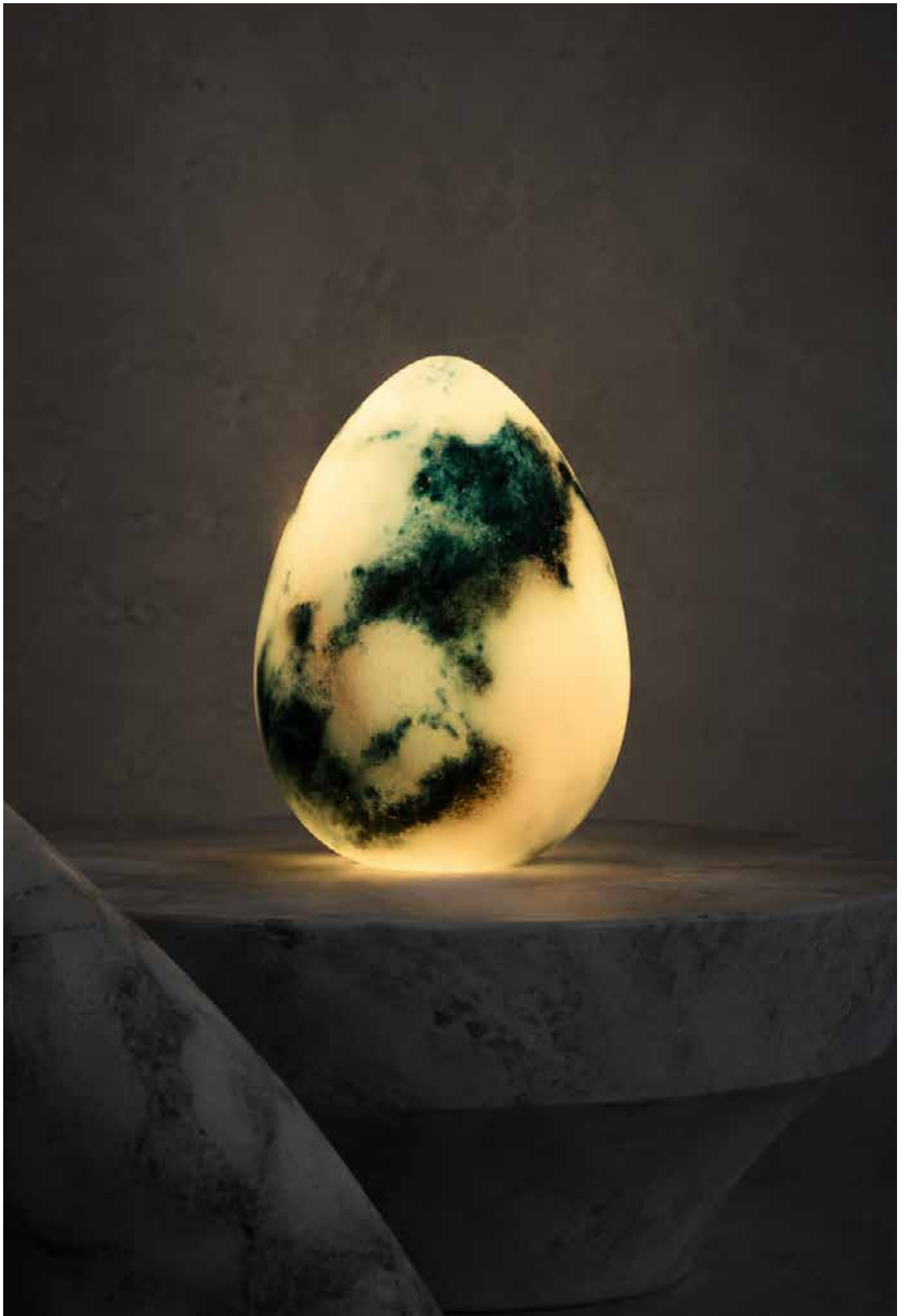

SPECIAL THANKING
in no particular order
And not limited to

PARTNERS
&
FRIENDS

Zaventem Ateliers
Atelier Lionel Jadot
David De Haguenu
Driton Memisi
Galerie Gosserez
Gallery 88
Gallery BooRoom
OWN
Gallery Philia
Eteline Collective
Galerie Augusta
GARDE
Workshop APD
MAD Paris
Sal de Menorca
Noemie V.D.B.
Clementine Leguerec
Laurie Melotte
Tara Menuet
Zoe VB

.
. .
. .



PHOTOGRAPHS

Frederic Vercryussen
Fred Uyttenhove
Lucile Dizier
Virgile Castro
Ludovic Maisant
Yen-An Chen
Studio Brinth
Tijs Vervecken
Photo BooRoom
David De Haguenu
Laurie Melotte
Zoe VB
Tara Menuet
Roxane Lahidji

Inside our workshop
Zaventem Ateliers- Belgium
2025

Graphic Design and Art Direction
Roxane Lahidji Hosseini



Bespoke sculptural vanity sink
120x60x68cm
2026